

Invacare® Action 3 NG

en Medium active wheelchair
User Manual

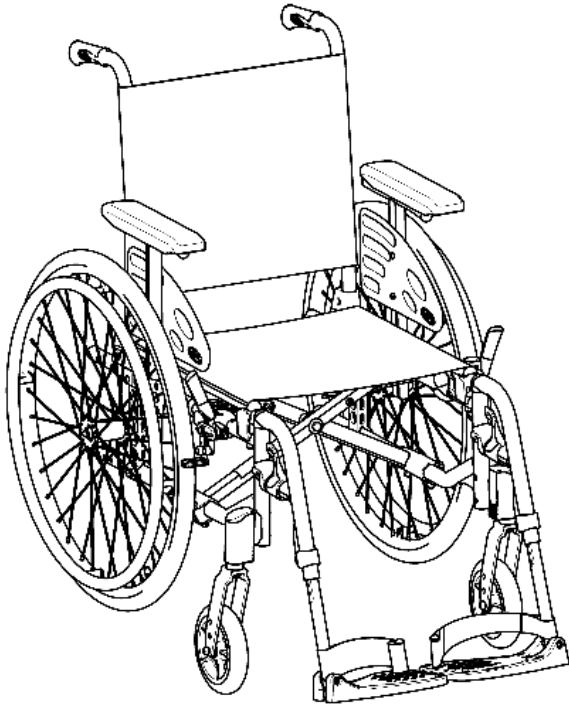

This manual **MUST** be given to the user of the product.
BEFORE using this product, read this manual and save for future reference.



Yes, you can.®

©2017 Invacare Corporation

All rights reserved. Reproduction, duplication or modification in whole or in part is prohibited without prior written permission from Invacare Corporation. Trademarks are identified by ™ and ®. All trademarks are owned by or licensed to Invacare Corporation or its subsidiaries unless otherwise noted.

Contents

1 General	5
1.1 Information about the User Manual	5
1.2 Symbols in this manual	5
1.3 Warranty	6
1.4 Limitation of liability	6
1.5 Standards and Regulations	6
1.6 Intended use	6
1.7 Service life	7
2 Safety	8
2.1 Safety information	8
2.2 Safety devices	9
2.3 Labels and symbols on the product	9
3 Components and their functions	11
3.1 Overview	11
3.2 Parking brakes	12
3.3 Backrest	13
3.3.1 Backrest cover	13
3.3.2 Backrest cover height	14
3.3.3 Fixed backrest	14
3.3.4 Folding backrest	14
3.3.5 Reclining backrest	15
3.3.6 Angle adjustable backrest (-15°/+15°)	16
3.4 Backbrace	17
3.4.1 Standard backbrace for the backrest	17
3.4.2 Folding backbrace for the backrest	18
3.5 Push handles	19
3.6 Mudguard	20
3.7 Armrests	20
3.7.1 Tubular armrest, height-adjustable, swiveling	21
3.7.2 Armrest, stepless height adjustable, removable	21
3.7.3 Armrest, height adjustable, removable	22
3.7.4 Armrest, foldable and removable	22
3.7.5 Armrest, height adjustable, foldable and removable	23
3.8 Leg rests	24
3.8.1 Swiveling leg rests	24
3.8.2 Swiveling, elevating leg rests	25
3.9 Anti-tipper	26
3.10 Tires	27
3.11 Seat cushion	28
4 Accessories	29
4.1 Comfort version	29
4.2 Transit version	29
4.3 Dual handrim DHR	30
4.4 One arm drive by lever	31
4.5 Posture belt	32
4.6 Headrest	34
4.7 Lateral positioning pads (for adjustable backrest cover only)	35
4.8 Tipper aid	36
4.9 Table tray	36
4.10 Half tray	37
4.11 Add a half tray cushion	38
4.12 Drip stand	39
4.13 Transfer kit wheels	40
4.14 Air pump	40
4.15 Passive illumination	41
4.16 Cane holder	41
5 Setup	42
5.1 Safety information	42
6 Using the wheelchair	43
6.1 Safety information	43
6.2 Braking during use	44
6.3 Move to/from the wheelchair	45
6.4 Driving and steering the wheelchair	46
6.5 Negotiating steps and kerbs	47
6.6 Going up and down stairs	49

6.7	Negotiating ramps and slopes	49
6.8	Stability and balance when seated.	51
7	Transport	52
7.1	Safety information.	52
7.2	Folding and unfolding the wheelchair	52
7.3	Lifting the wheelchair	53
7.4	Removing and fitting the rear wheels	54
7.5	Transporting the occupied wheelchair in a vehicle	55
8	Maintenance	61
8.1	Safety information.	61
8.2	Maintenance Schedule	61
8.3	Cleaning	63
8.4	Disinfection.	64
9	Troubleshooting	65
9.1	Safety information.	65
9.2	Identifying and repairing faults	66
10	After Use	68
10.1	Storage	68
10.2	Re-use	68
10.3	Disposal	68
11	Technical data	69
11.1	Dimensions and weight	69
11.2	Materials.	70
11.3	Environmental conditions.	71

1 General

1.1 Information about the User Manual

Thank you for choosing an Invacare wheelchair.

This User Manual contains important information about using the wheelchair. In order to ensure safety when using your wheelchair, read the User Manual carefully and follow the safety information.

The information contained in this manual is subject to change without notice.

If your vision is impaired, you can view the user manual as a PDF file on the Internet at www.invacare.com and enlarge it on-screen as required. If you cannot enlarge the texts and graphics sufficiently, please contact the Invacare distributor for your country;

→ addresses on the reverse of this document. If necessary, we will provide you with a high resolution PDF file of the user manual. Moreover, you can have the PDF file read out to you with the aid of suitable programs using special language functions on your computer (e.g. in Adobe®Reader®X: Shift+Ctrl+Y).



The equipment of your wheelchair may differ from the descriptions and diagrams given here due to the wide range of models available.

For latest important product information (eg.: product safety notices, product recalls, ...), please refer to our website at www.invacare.eu.com, your local specialized dealer or contact Invacare in your country (for addresses, see back page of this manual).

1.2 Symbols in this manual

In this User Manual warnings are indicated by symbols. The warning symbols are accompanied by a heading that indicates the severity of the danger.



WARNING!

Indicates a hazardous situation that could result in serious injury or death if it is not avoided.



CAUTION!

Indicates a hazardous situation that could result in minor or slight injury if it is not avoided.



IMPORTANT!

Indicates a hazardous situation that could result in damage to property if it is not avoided.



Gives useful tips, recommendations and information for efficient, trouble-free use.



This product complies with Directive 93/42/EEC concerning medical devices. The launch date of this product is stated in the CE declaration of conformity.



Manufacturer

1.3 Warranty

Invacare guarantees that their wheelchairs are free from defects and are fully functional. The warranty covers all faults and defects which are verifiably attributable to faulty construction, substandard materials or poor workmanship. Warranty claims against the manufacturer may only be made by the distributor and not by the user of the product.

The warranty does not cover normal wear and tear, the consequences of improper handling or damage, poor maintenance and incorrect assembly or commissioning by the purchaser or a third person or faults which are attributable to circumstances beyond our control. Wearing parts are not covered by the guarantee. The warranty is voided if modifications are made to the product which were not authorized and not performed by the specialist dealer or if inappropriate accessories or spare parts are used. The warranty does not cover consequential costs arising from the rectification of defects such as freight and travel expenses, labor costs, fees etc.

The term of the warranty is 24 months.

Furthermore, the terms and conditions are part of the general terms and conditions particular to the individual countries in which the product is sold.

1.4 Limitation of liability

Invacare accepts no liability for damage arising from:

- Non-compliance with the User Manual
- Incorrect use
- Natural wear and tear

- Incorrect assembly or set-up by the purchaser or a third party
- Technical modifications
- The usage of unapproved 3rd party accessories instead of a tested and approved Invacare accessories
- Unauthorized modifications and/or use of unsuitable spare parts

A written authorisation of Invacare must be obtained before installing additional adaptations on an Invacare wheelchair. Otherwise no liability claims can be made.

1.5 Standards and Regulations

Quality is fundamental to the company's operation, working within the disciplines of ISO 9001 and ISO 13485.

The wheelchair has been tested in accordance with EN 12183. It includes a test for flammability (EN 1021-2 or ISO 8191-2).

Invacare is continuously working towards ensuring that the company's impact on the environment, locally and globally, is reduced to a minimum. We use only REACH compliant materials and components.

1.6 Intended use

The medium active wheelchair is propelled manually and should only be used for independent or assisted transport of a disabled person with mobility difficulties. This manual wheelchair is intended to provide mobility to persons ages 15 and up (adolescents and adults) with a maximum weight capacity of 125 kg. The device is indicated to provide mobility to persons limited to sitting position. When used without an assistant, it should only be used by persons who

are physically and mentally able to use the wheelchair safely (e.g. to propel themselves, steer, brake). The wheelchair should only be used on level ground and accessible terrain, as well as indoors.



This medium active wheelchair needs to be subscribed and fit to your specific health condition.

**WARNING!**

Any other or incorrect use could lead to hazardous situations.

There are no contraindications known, when using the wheelchair as intended.

**CAUTION!**

- In some configurations, the overall dimensions of the wheelchair when it is ready for use exceed the authorized limits, the access to emergency escape routes is not possible.
- In some configurations, the wheelchair exceed the size recommended for travelling by train in the EU.



Theft and metal detection systems: in seldom cases the materials used in the wheelchair may activate theft and metal detection systems.

1.7 Service life

The expected service life is five years, presuming that the product is used daily and in accordance with safety instructions, maintenance instructions and intended use, stated in this manual.

2 Safety

2.1 Safety information

This section contains important safety information for the protection of the wheelchair user and assistant and for safe, trouble-free use of the wheelchair.



WARNING!

Risk of accidents and serious injury

Accidents with resulting serious injury can occur if the wheelchair is wrongly adjusted.

- Adjustments at the wheelchair always must be carried out by an authorized dealer.



WARNING!

Risk due to driving style being unsuitable for the conditions

There is a risk of skidding on wet ground, gravel or uneven terrain.

- Always adjust your speed and driving style to the conditions (weather, surface, individual ability, etc.).



WARNING!

Risk of injury

In a collision you could sustain injury to parts of your body that extend beyond the wheelchair (e.g. feet or hands).

- Avoid an unbraked collision.
- Never drive into an object head-on.
- Drive carefully through narrow passages.



WARNING!

Risk due to wheelchair being out of control

At high speed you could lose control of your wheelchair and overturn.

- Never exceed a speed of 7 km/h.
- Avoid collisions in general.



WARNING!

Risk of tilting

The position of the rear wheel axle and the angle of your wheelchair's backrest are two of the key adjustments that can affect your stability whilst sitting in the wheelchair.

- These changes, any front wheels position and/or angle fork adjustments to the set-up of your wheelchair must only be performed at the direction of a competent person who has fully risk assessed the implication of any changes to the wheelchair configuration. Therefore, consult with your authorized dealer.



CAUTION!

Risk of burning

The wheelchair components can heat up when exposed to external sources of heat.

- Do not expose the wheelchair to strong sunlight before use.
- Before usage, check all components that come into contact with your skin for their temperature.

**CAUTION!****Risk of getting fingers caught**

There is always a risk of getting, e.g. fingers or arms, caught in the moving parts of the wheelchair.

- Make sure when activating the folding or insertion mechanisms of moving parts, such as the removable axle of the rear wheel, folding backrest or anti-tipper, that nothing becomes caught.

**CAUTION!****Risk of tipping**

The hanging of additional load (back pack or similar items) onto your chair backposts can affect the rearward stability of your wheelchair, especially when used in combination with angle adjustable backrests.

- Invacare strongly recommend the use of anti-tipper (available as an option) when using your backposts with additional load.

2.2 Safety devices

**WARNING!****Risk of accidents**

Safety devices that are incorrectly set or no longer working (brakes, antitipper) can cause accidents.

- Always check that the safety devices are working before you use the wheelchair and have them checked regularly by the authorized dealer.

The functions of the safety devices are described in chapter 3 *Components and their functions*, page 11.



2.3 Labels and symbols on the product

Identification label

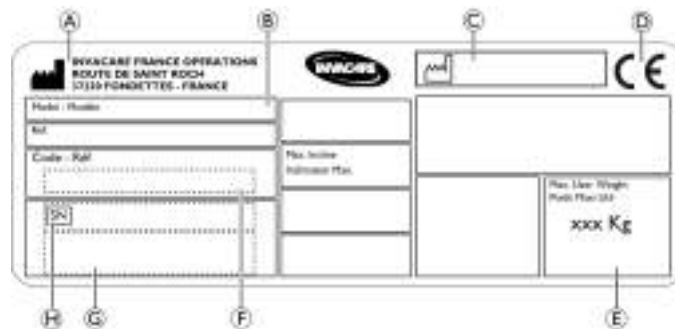
The identification label is attached to the frame of your wheelchair and gives the following information:





(A)	Manufacturer's address
(B)	Product description
(C)	Date of manufacture
(D)	CE mark
(E)	Maximum user weight
(F)	Part number
(G)	Serial number barcode
(H)	Serial number

	<p>Read user manual</p>
	<p>Indicates a hazardous situation that could result in serious injury or death if it is not avoided.</p>

Snap hook symbols

Depending on the configuration, some wheelchairs may be used as a seat in a motor vehicle, some may not.

 <p>ISO 7175-19</p>	<p>Tie-down positions where the restraint system straps must be placed in case of using the wheelchair as a seat in a motor vehicle, see section 7.5 <i>Transporting the occupied wheelchair in a vehicle</i>, page 55.</p>
--	---

	<p>WARNING Symbol This wheelchair is not configured for passenger transport in a motor vehicle. This symbol is attached to the frame close to the identification label.</p>
---	--

3 Components and their functions

3.1 Overview

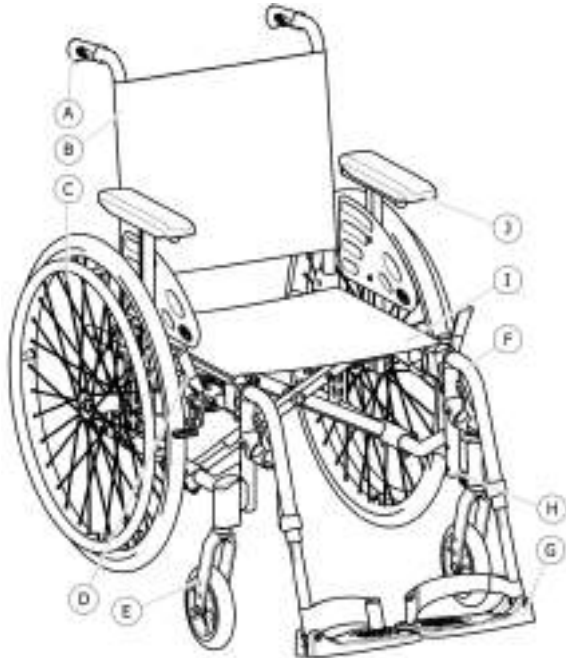

Ⓐ	Push handle
Ⓑ	Back
Ⓒ	Rear wheel with handrim
Ⓓ	Parking brake
Ⓔ	Front wheel fork with front wheel
Ⓕ	Leg rests, swiveling
Ⓖ	Footrest
Ⓗ	Frame
Ⓘ	Seat
⓵	Armrest

Short description

This is a medium active wheelchair with crossbar folding mechanism and swiveling leg rests.

- i** The equipment of your wheelchair may differ from the diagram as each wheelchair is manufactured individually to the specifications in the order.

3.2 Parking brakes

The parking brakes are used to immobilize the wheelchair when it is stationary to prevent it from rolling away.



WARNING!

Risk of overturning if you brake sharply

If you apply the parking brakes while you are moving, the direction of movement can become uncontrollable and the wheelchair may stop suddenly, which can lead to a collision or to you falling out.

- Never apply the parking brakes while you are moving.



WARNING!

Risk due to wheelchair being out of control

- The parking brakes must be operated simultaneously.
- Do not apply the parking brakes to slow down the wheelchair.
- Do not lean on the parking brakes for support or transfer.



WARNING!

Risk of overturning

The parking brakes will not operate correctly unless there is sufficient air in the tires.

- Ensure the correct tire pressure, *3.10 Tires, page 27.*



CAUTION!

Risk of pinching or crushing

There may be a very small gap between the rear wheel and the parking brake with the risk that you could trap your fingers.

- Keep your fingers away from movable parts when using the brake, always keep your hand on the brake lever.



The distance between the brake shoe and the tire can be adjusted. The adjustment must be carried out by an authorized dealer.

Standard brake

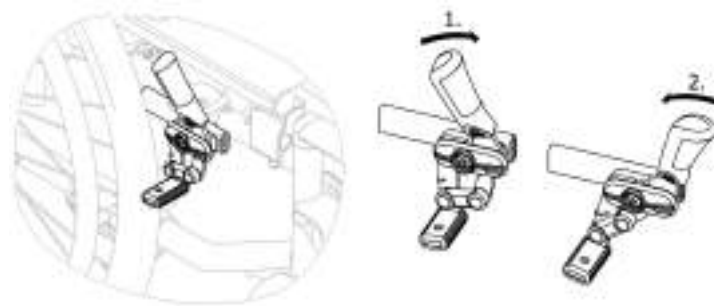

1. To apply the brake, push the brake lever forwards as far as possible.
2. To release the brake, pull the brake lever backwards.



The lever of the push handle can be folded back to facilitate transfers. To do so, pull up the lever and fold it backwards.

Pull brake

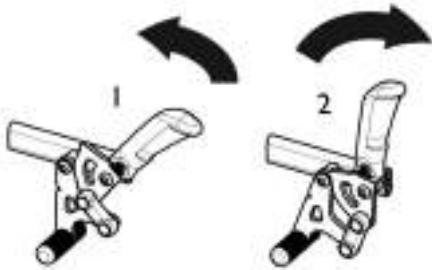

1. To apply the brake, pull the brake lever backwards as far as possible.
2. To release the brake, push the brake lever forwards.



The lever of the push handle can be folded back to facilitate transfers. To do so, pull up the lever and fold it backwards.

One arm drive brake (available as an option)

This brake allows the user to immobilise the wheelchair with a single arm (One brake lever; right or left hand).



WARNING!

Risk due to wheelchair being out of braking control

In stiff slopes you can lose braking control of your wheelchair and overturn.

- Do not take slopes exceeding 5° to ensure perfect braking control of the wheelchair.

3.3 Backrest

There are three types of backrest (Fixed, Folding and Reclining) available.

3.3.1 Backrest cover

You can adjust the tension of the backrest cover as required.

Adjusting the backrest cover

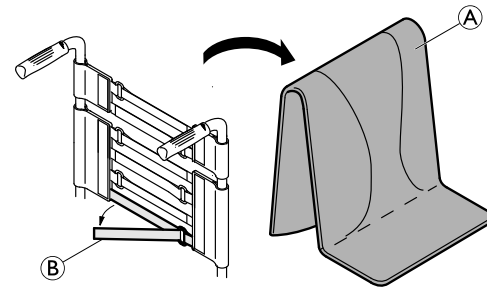

1. Remove the backrest cushion **A**.
2. Loosen the Velcro® tapes **B** on the rear of the backrest cover by simply pulling on them.
3. Tighten or loosen the tapes as required then reattach them.



WARNING!

Risk of tipping

If the bands are set very loose, the tipping point of your wheelchair is changed for the worse.

- Ensure that the bands are set correctly.

! **IMPORTANT!**

– Do not overtighten the bands; this is to ensure that the geometry of the wheelchair is not changed.

! **IMPORTANT!**

– Only ever tighten the bands when the wheelchair is unfolded.

 A simple backrest cover is available for all backrest types. These covers are not adjustable.

3.3.2 Backrest cover height

The backrest cover height can be adjusted for all three types of backrest.



WARNING!
Risk of tipping

The hanging of additional load (back pack or similar items) onto your wheelchair back posts can affect the rearward stability of your wheelchair. This can cause the chair to tip backwards causing injury.

– Therefore, Invacare strongly recommend the use of anti-tippers (available as an option) when using your back posts with additional load (back pack or similar items).

 The height of the backrest cover can be adjusted on the back posts. The adjustment must be carried out by an authorized dealer.

3.3.3 Fixed backrest

Fixed backrest of 0° and 7°: these two backrests do not require adjustments.

3.3.4 Folding backrest

To save space for transporting the wheelchair, the backrest can be folded.



Folding and unfolding the backrest

1. Operate lever **A** by pulling it and fold the top of the backrest.
2. To return to the initial position, bring the top in the vertical position; it locks automatically.

3.3.5 Reclining backrest

To achieve a more comfort position for the user, the backrest can be reclined.

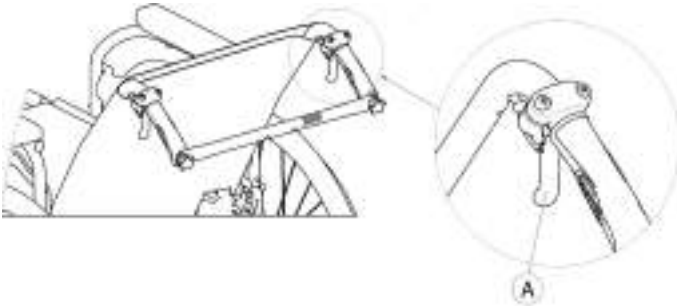

WARNING!

Risk of tipping

Do not move the wheelchair when the backrest is in reclined position.

- Invacare strongly recommend the use of anti-tippers (available as an option) when the backrest is in reclined position .

Backrest angle

The angle of the backrest can be adjusted in four steps (0° to 30°) with the mechanical version, and stepless with the gas struts version.



WARNING!

Risk of injury

- Always make these adjustments before the user settles down in the wheelchair to prevent injuries.
- Invacare strongly recommends the use of anti-tippers (available as an option) in combination with all rear wheel positions when you use your backrest with an angle of 12° and more



IMPORTANT!

- Push on the backrest canes before operating the levers, this is to release the auto-locked security system.

1. Release the auto-locked system by pushing on the backrest canes.
2. Simultaneously pull the levers Ⓐ to provides the same angle on both sides.
3. Release the levers when you reach the desired angle.

3.3.6 Angle adjustable backrest (-15°/+15°)

The angle of the backrest can be adjusted from -15° to +15° (step less).

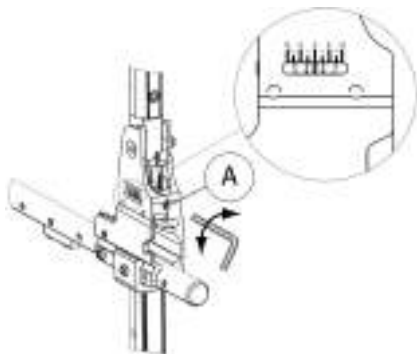

1. Adjust the backrest angle thanks to the adjustable screw **A**.
2. Turn 5 mm Allen key clockwise to obtain a negative angle.
3. Alternatively, turn 5 mm Allen key under clockwise to obtain a positive angle.
4. Ensure both adjustments to the desired angle are equal on both sides.

Invacare recommends that the backrest angle adjustment is carried out by an authorized dealer.



WARNING!

Risk of tipping

Do not move the wheelchair when the backrest is in reclined position.

- Invacare strongly recommend the use of anti-tippers (available as an option) when the backrest is in reclined position .



WARNING!

Risk of injury

- Invacare strongly recommends the use of anti-tippers (available as an option) in combination with all rear wheel positions when you use your backrest with an angle of 12° and more



WARNING!

Risk of serious injury

- Tilting up with a user of more than 125 kg can fatigue, bend or break the wheelchair backrest.
- Avoid tilting up the wheelchair with a user weight of more than 125 kg.



CAUTION!

Risk of uncomfortable posture

An angle less than 90° between the seat and the backrest is uncomfortable for certain users.

- This adjustment must be performed by a professional technician upon agreement by a prescribing physician. Please consult with your dealer.

3.4 Backbrace

There are two types of backbraces (Standard backbrace and Folding backbrace) available.

3.4.1 Standard backbrace for the backrest

The backbrace links the two push handles, provides tension to the backrest upholstery and must always be in position on recliner versions.



CAUTION!

- Do not use the backbrace to push the wheelchair. The backbrace is not a push bar!
- Do not attempt to lift the wheelchair using the backbrace; it may come loose and it could break.
- Keep your fingers away from movable parts and sharp edges to prevent injuries.

Folding the backbrace

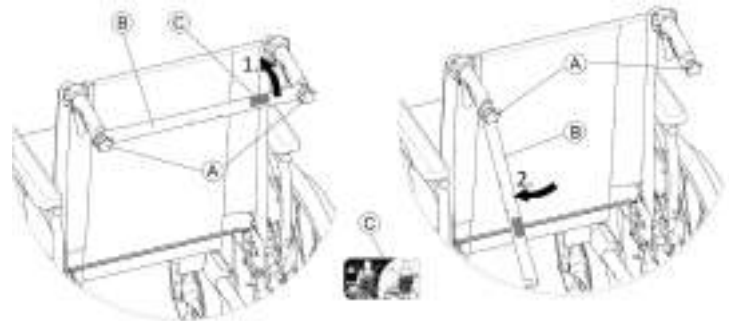

1. Slightly loosen the two hand screws (A), pull up the backbrace (B) and swivel it downwards along the backrest (on right or left hand).
2. Fold the backbrace (B) until it is in vertical position.

Unfolding the backbrace

1. Fold the backbrace ⑥ upwards.
2. Align the backbrace ⑥ with the push handle and push it down on the hand screw ④.
3. Firmly tighten the hand screw ④ and make sure that the TWO hand screws ④ are properly tightened.



It is important to ensure that the backbrace is correctly fitted and engaged at all times when the chair is in use. It should not be left hanging loose (see label ③ on the backbrace).



3.4.2 Folding backbrace for the backrest

An optional folding backbrace is available to increase the rigidity of the backrest on wheelchairs with large back heights or widths.



CAUTION!

– Do not use the folding backbrace to lift or push the wheelchair. It could break.

Folding the backbrace



1. Unlock the folding backbrace by pushing the joint ① slightly downwards.
2. Fold the backbrace downwards.



The folding backbrace will automatically release when the chair is folded.

Unfolding the backbrace

1. Fold the backbrace upwards.
2. Lock the folding backbrace by pulling the joint ① slightly upwards.

3.5 Push handles

! IMPORTANT!

- Always check the push handles before using the wheelchair, as to whether the hand grips are secure, cannot be turned and cannot be pulled off.

Height adjustable, rear set push handles (optional)

The height adjustable, rear set push handles allow any assistant to adjust the handles to a comfortable level.

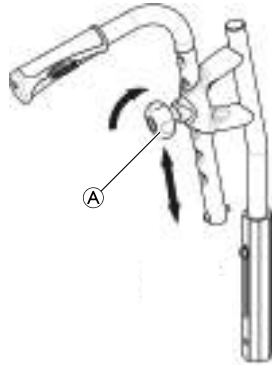

1. To set the height of the push handles, loosen the knob ①, push the handle to the desired position and tighten the knob again.



CAUTION!

- If the knob is not correctly tightened, the push handle could accidentally come off the backrest tube while pushing it upwards.
- Make sure that the knob is firmly tightened.

Height adjustable, integrated push handles (optional)

The height adjustable, integrated push handles allow any assistant to adjust the handles to a comfortable level.

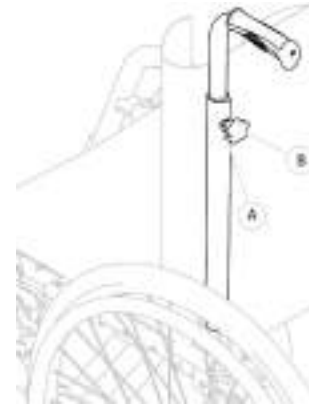

1. To set the height of the push handles, loosen the knob ①, push the handle to the desired position and tighten the knob again.

**CAUTION!**

If the knob is not correctly tightened, the push handle could accidentally come off the backrest tube while pushing it upwards.

- Make sure that the knob is firmly tightened.

3.6 Mudguard

In order to prevent dirt from the wheels spraying upwards, a removable mudguard can be fitted. The position of the mudguard can be adjusted.

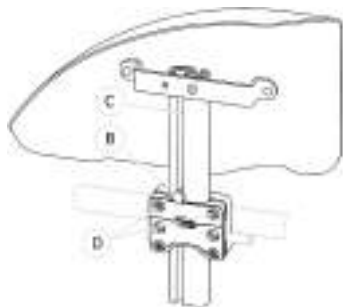

Removing

1. Pull the mudguard upwards out of the holder.
2. To adjust how easy or difficult it is to pull the mudguard out of the holder, change the degree to which the screws (D) are tightened.

Fitting

1. Push the mudguard into the holder.

Adjusting the height

1. Loosen the screw (B) with 10 mm spanner in the groove (C) of the armrest tube.
2. Move the armrest upwards or downwards until you reach the desired height, while keeping screw (B) in place (at the top edge of the holder).
3. Tighten the screw (B) (5–6 Nm).
4. Perform the setting on both sides.

3.7 Armrests

**WARNING!**

The armrest does not engage into the wheelchair.
– Therefore do not hold it in order to lift the wheelchair.

**CAUTION!****Risk of pinching**

– Keep your fingers away from movable parts during removing, fitting or adjusting the armrest.

3.7.1 Tubular armrest, height-adjustable, swiveling

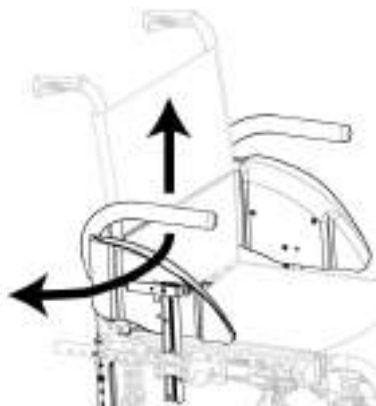

Removing

1. Raise the tubular armrest and pull it upwards out of the holder.

Fitting

1. Push the tubular armrest into the holder.

Adjusting the height

1. Pull the tubular armrest out of the holder.
2. Loosen the screw on the tube of the armrest and screw it back in at the desired height.
3. Push the tubular armrest back into the holder.
4. Perform the setting on both sides.

Swiveling

1. Raise the armrest a little and swivel it outwards.

1608467-B

3.7.2 Armrest, stepless height adjustable, removable

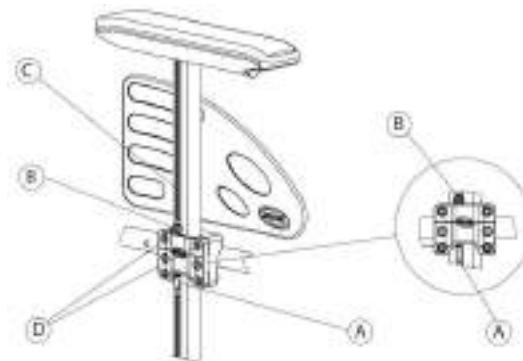

Removing

1. Apply the parking brake on both sides.
2. Previously press on the locking mechanism **A** located at the bottom of the armrest vertical bracket.
3. Pull the armrest by the arm cushion out of the holder.
4. To adjust how easy or difficult it is to pull the armrest out of the holder, change the degree to which the screws **D** are tightened.

Fitting

1. Push the armrest into the holder.

Adjusting the height

1. Loosen the screw **B** with 5 mm Allen key in the groove **C** of the armrest tube.
2. Move the armrest upwards or downwards until you reach the desired height, while keeping screw **B** in place (at the top edge of the holder).

3. Tighten the screw ⑥ (5–6 Nm).
4. Perform the setting on both sides.

3.7.3 Armrest, height adjustable, removable

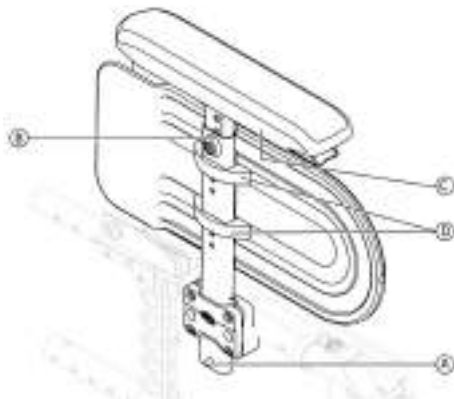

Removing

1. Previously press on the locking mechanism ① located at the bottom of the armrest vertical bracket.
2. Pull the armrest by the arm cushion out of the holder.

Fitting

1. Push the armrest into the holder.

Adjusting the armpad height

1. Loosen the screw ⑥ with 5 mm Allen key at top of the armrest tube.
2. Move the armrest upwards or downwards until you reach the desired height, while keeping screw ⑥ in place.

3. Tighten the screw ⑥ (5–6 Nm).
4. Perform the setting on both sides.

Adjusting the armpad depth

1. Loosen the 2 screws ③ below the armrest bracket.
2. Move the armrest frontwards or rearwards until you reach the desired depth, while keeping screw ③ in place.
3. Tighten the 2 screws ③ (1,5–2 Nm).
4. Perform the setting on both sides.

Adjusting the side protection height

1. Loosen the 2 screws of the side protection clamps ④.
2. Move the side protection upwards or downwards until you reach the desired height.
3. Tighten the 2 screws of the side protect clamps ④ (0,7–1,2 Nm).
4. Perform the setting on both sides.

3.7.4 Armrest, foldable and removable



Folding

1. Grip the armrest by the armpad or by the front curve and fold it back.

Front removing

1. Press and hold the armrest release push pin ① at the front.
2. Remove armrest from armrest socket by pulling straight up and fold it back.

Front fitting

1. Push the armrest down and until the front release button ② snaps into its armrest socket hole.
2. Ensure button protrudes fully through socket hole.

Rear removing

1. Remove armrest from armrest bracket ④ by pulling straight up on the armrest.

Rear fitting

1. Position armrest support ③ over rear armrest bracket ④.
2. Push the armrest down until a clear “click” is heard when it’s locked into the armrest bracket ④.

3.7.5 Armrest, height adjustable, foldable and removable

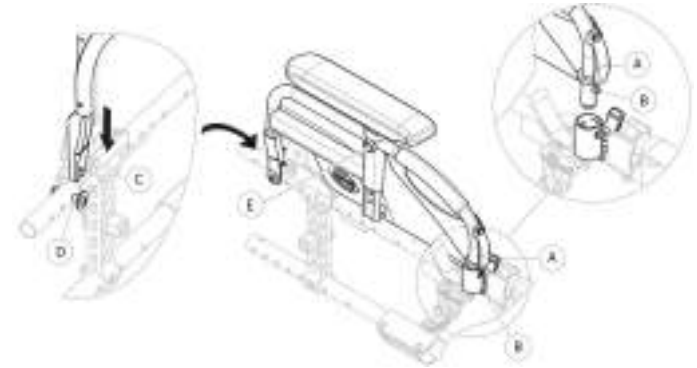

Folding

1. Grip the armrest by the armpad or by the front curve and fold it back.

Front removing

1. Press and hold the armrest release bracket ① at the front.
2. Remove armrest from armrest socket by pulling straight up and fold it back.

Front fitting

1. Push the armrest down and until the front release button ② snaps into its armrest socket hole.
2. Ensure button protrudes fully through socket hole.

Rear removing

1. Remove armrest from armrest bracket ④ by pulling straight up on the armrest.

Rear fitting

1. Position armrest support ③ over rear armrest bracket ④.
2. Push the armrest down until a clear “click” is heard when it’s locked into the armrest bracket ④.

Adjusting the height

1. After loosening the fixing screw ⑤ with 5 mm Allen key or alternatively the thumbscrew, if present.
2. Adjust the height and tighten the fixing screw ⑤ (5 Nm) or firmly tighten the thumbscrew, into the desired position.
3. Perform the setting on both sides.

3.8 Leg rests



WARNING!

Risk of injury

- Never lift the wheelchair by the footrest supports or leg rests.



CAUTION!

Risk of pinching

- Keep your fingers away from movable parts during folding, disassembling or adjustment.



IMPORTANT!

Risk of damage to the leg rest mechanism

- Do not place anything heavy, or let children sit on the leg rest.

3.8.1 Swiveling leg rests

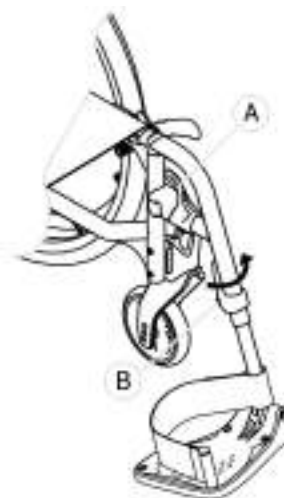

Swiveling

1. Activate the release lever ① and swivel the leg rests to the outside.

Swiveling forwards

1. Swivel the leg rest forwards until it engages.

Unhinging

1. Activate the release lever ①.
2. Pull the leg rest upwards.

Hinging

1. Hinge the leg rest on the front of the frame and swivel it forwards until it engages.

3.8.2 Swiveling, elevating leg rests

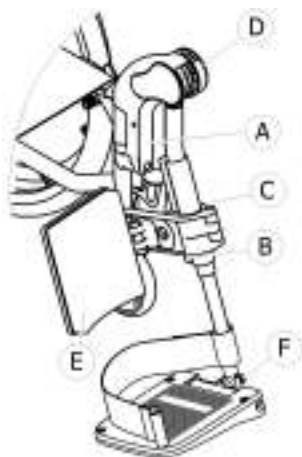

Swiveling

1. Activate the release lever **(A)** and swivel the leg rests to the outside.

Swiveling forwards

1. Swivel the leg rest forwards until it engages.

Unhinging

1. Activate the release lever **(A)**.
2. Pull the leg rest upwards.

Hinging

1. Hinge the leg rest on the front of the frame and swivel it forwards until it engages.

Angle adjustment

There are seven preset positions available for angle adjustment.

1. Rotate the knob **(D)** with one hand while supporting the leg rest with your other hand.
2. When a suitable angle is obtained, let go off the knob and the leg rest will lock into the desired position.

Calf pad adjustment

The calf pad **(E)** swings away during transfers and has three height adjustment options.

Height adjustment:

1. After loosening the fixing screw **(C)** adjust to the desired height and firmly tighten the fixing screw.

The calf pad has two depth adjustment options.

Depth adjustment:

Invacare recommends that depth adjustment is carried out by an authorized dealer.

Foot plate adjustment

There are two different foot plates available.

- Height adjustable foot plates
 1. After loosening the fixing screw **(B)** with 5 mm Allen key.
 2. Adjust the height and tighten the fixing screw **(B)** (5 Nm) into the desired position.

- Height, depth and angle adjustable foot plates
 1. After loosening the fixing screw ⑤ with 5 mm Allen key.
 2. Adjust the depth and angle positions and firmly tighten the fixing screw ⑤ (12 Nm) into the desired position.

Invacare recommends that footplate adjustment is carried out by an authorized dealer.

 To ensure a good position of the feet, two types of straps can be provided; the heel strap (serial) and the calf strap (optional) attached to the leg rest support. Both adjustable by Velcro® fasteners.

3.9 Anti-tipper

An anti-tipper prevents the wheelchair from tipping backwards.



WARNING! **Risk of overturning**

Anti-tippers that are incorrectly set or no longer working can lead to overturning.

- Always check that the anti-tipper is working before using the wheelchair and have it set or readjusted by an authorized dealer when required.
- In some configurations, the static stability of the wheelchair may be lower than 10°; Invacare strongly recommends the use of anti-tipper (available as an option).



WARNING!

Risk of overturning

On uneven or soft ground, the anti-tipper can sink into potholes or directly into the ground, thereby curtailing or eliminating its safety function.

- Only use the anti-tipper when travelling on even and firm ground.

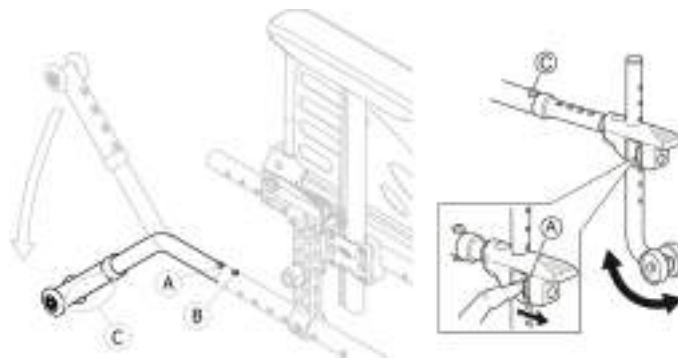

Activating the anti-tipper

1. Release the spring button ① and swivel the anti-tipper downwards until it engages and the front release button ② snaps into the frame hole.
2. Ensure front release button ② protrudes fully through frame hole.



WARNING!

Risk of tipping

An activated anti-tipper can catch when negotiating a step or an edge.

- Always deactivate the anti-tipper before driving over a step or kerb.

Deactivating the anti-tipper

1. Release the spring button **Ⓐ** and swivel the anti-tipper upwards until it engages and the front release button **Ⓑ** snaps into the frame hole.



WARNING!

Risk of overturning

- Always advise the user if you deactivate the anti-tippers.



There is a red label on the housing of the anti-tipper, this label shows when the anti-tipper is inactivated. When the anti-tipper is correctly activated, the red label will be concealed.

Setting the height



WARNING!

Risk of overturning

- The adjustments of the anti-tipper must be carried out by an authorized dealer.



This adjustment is required with reference to the position and diameter of the rear wheel as well as the user conditions and his particular safety limits.





Make sure that the anti-tipper device is fitted correctly on each side (if applicable), the spring button **Ⓐ** and fixation **Ⓒ** must be locked into position.

3.10 Tires

The ideal pressure depends on the tire type:

Tire	Max. pressure		
	bar	kPa	psi
Pneumatic tire, grey: 560 mm (22"); 610 mm (24")	4 bar	400 kPa	58 psi
Non marking pneumatic tire (grey, sidewall black): 560 mm (22"); 610 mm (24")	7 bar	700 kPa	101 psi
Schwalbe® Marathon Plus Evolution tire: 610 mm (24")	10 bar	1000 kPa	145 psi
Solid tire, grey: 560 mm (22"); 610 mm (24"), black only: 610 mm (24")	-	-	-
Solid tire, grey/black: 150 mm (6"); 200 mm (8"), grey only: 125 mm (5")	-	-	-
Pneumatic tire, grey: 150 mm (6"); 200 mm (8")	2.5 bar	250 kPa	36 psi

 The compatibility of the tires listed above depends on the configuration and/or model of your wheelchair.

 The size of the tire is mentioned on the sidewall of the tire. The change of appropriate tires must be carried out by an authorized dealer.



CAUTION!

– The tires pressure have to be equal in both wheels to avoid a less driving comfort, to keep the brakes efficiency and an easy propelling of the wheelchair.

3.11 Seat cushion

A suitable cushion is recommended to provide an even pressure distribution on the seat.



CAUTION!

Adding a cushion to the seat will raise your height above the ground and can affect your stability in all directions. If a cushion is changed it may also change the user's stability. If the thickness of the cushion is changed, a complete set up of the wheelchair need to be done by an authorized dealer.

– We recommend to use an Invacare or Matrix cushion with anti-slip base cover in order to prevent sliding.

4 Accessories

4.1 Comfort version

It is made up of a rigid shell (A) and a preformed foam cushion (B) which is locked in place by Velcro® fasteners. The backrest shell is removable to allow the folding of the wheelchair. The comfort version is always delivered in passive rear wheel position for a better stability.



WARNING!

Risk of injury

– Never lift the wheelchair by the backrest shell.



CAUTION!

Risk of pinching

– Keep your fingers away from movable parts during folding, disassembling or adjustment.

Remove the backrest shell



1. Slightly loosen the two hand screws (C) .
2. Slide the levers (D) inwards until they are in open position.
3. Disengage the hooks (E) from their supports.

Install the backrest shell

1. Engage the hooks (E) into their supports.
2. Slide the levers (D) outwards until they are in lock position.
3. Firmly tighten the two hand screws (A) and make sure that the TWO hand screws (A) are properly tightened .



It is recommended that this operation be performed only by the attendant. It is important to ensure that the backrest shell is correctly fitted and engaged at all times when the chair is in use. Make sure the backrest cushion Velcro® fasteners are in good state and well positioned.

4.2 Transit version

The transit version is designed to be driven only by the attendant. To facilitate sideways transfers and save space, the wheelchair is equipped with rear wheels of 12" (305 mm).



WARNING!

Risk of accident

The manual brakes will not operate correctly unless there is sufficient air in the pneumatic tires.

– Ensure the correct tire pressure, *3.10 Tires, page 27.*

 The distance between the brake shoe and the tire can be adjusted. The adjustment must be carried out by an authorized dealer.

The manual brakes (optional drum brake) are only accessible to the attendant; operate the handle (A) to lock the wheelchair in parking position.

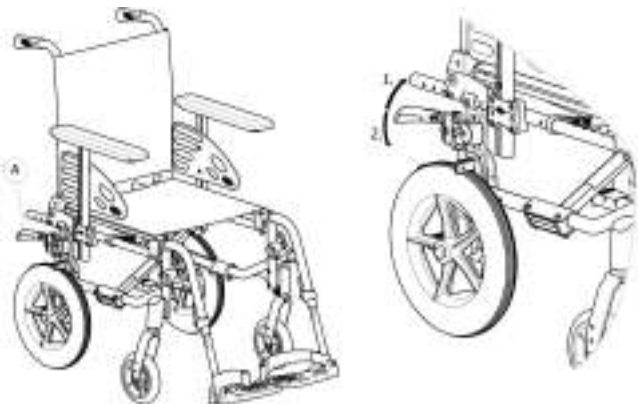

1. To apply the brake, pull the brake lever upwards as far as possible.
2. To release the brake, push the brake lever downwards.

For drum brake, please read section 6.2 *Braking during use*, page 44.

 Transit version equipped with a reclining backrest is always fitted with anti-tippers.

4.3 Dual handrim DHR

This quick release dual handrim system (left or right hand) allows the user to drive the wheelchair with a single arm using two handrims on the same wheel with 2 possible side positions of the small handrim. The user catches both handrims to propel the wheelchair forward or backwards; turns on the LH or RH side by gripping the large or the small handrim only. The DHR system is always delivered in passive rear wheel position for a better stability.



CAUTION! **Risk of injury**

– it is essential that the button (A) is fully engaged providing perfect locking of the rear wheels.

Remove rear wheels

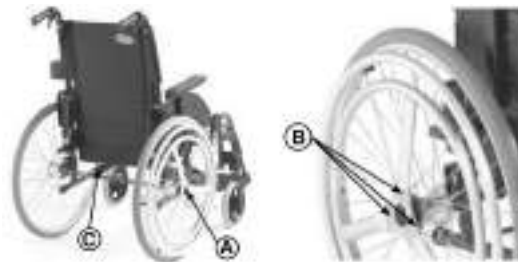

The removable and interchangeable rear wheels facilitate transport as well as change of the control side.

1. Push the button (A) .
2. Remove the wheel from its support on both sides.
3. Reverse procedure to reinstall the rear wheels.

 Two positions of the small handrim are possible to facilitate the propulsion: internal position or external position. Make sure that 3 screws **ⓑ** are locked into position.



CAUTION!

Risk of injury

- Its recommended that the change of control side and position of the small handrim must be carried out by an authorized dealer.

Disengage the telescopic rearwheel shaft

To fold the wheelchair it is necessary to disengage the telescopic rearwheel shaft **Ⓒ** .

1. Disengage the telescopic shaft **Ⓒ** by sliding one part inside the other.
2. To facilitate this operation move the small handrim forwards to backwards.
3. Reverse the procedure to reinstall.



CAUTION!

Risk of accident

- The telescopic rearwheel shaft **Ⓒ** is an integral part of the wheelchair and the user will be unable to propel the wheelchair without it.

4.4 One arm drive by lever

The One arm drive by lever control system (left or right hand) allows the user with low muscular tone to propel the wheelchair with a single arm. The user grips the drive motion lever which propels the wheelchair frontwards or backwards (reversing gear lever **Ⓐ**, central position is the neutral gear) thanks to an in and out movement; steering is performed by simply turning the drive motion lever to the LH/RH side and braking by pulling the drive motion lever backwards. The OADL system is always delivered in passive rear wheel position for a better stability.



The drive motion lever can be removed to facilitate transfer or to move next to a table ; loosen the handle lever **Ⓑ** and pull up the drive motion lever. Reverse the procedure to reinstall.



The manual brake is always located opposite to the control system.



CAUTION!

Risk of pinching or crushing

- There may be a very small gap between the rear wheel and the transmissions links with the risk that you could trap your fingers.
- Keep your fingers away from movable parts when using the OADL system, always keep your hand on the hand lever.

Adjust the propulsion effort

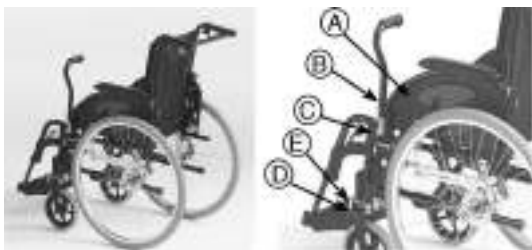

The adjustment is performed by moving the transmission links sleeve on the drive motion lever.

1. Slightly loosen the handle lever © .
2. Slide the transmission links sleeve downwards to reduce the stress.
3. Firmly tighten the handle lever © and makes sure that the handle lever © is properly tighten .



CAUTION!

Risk of pinching or crushing

- Make sure that the 2 handle levers © and © are properly positioned so that they are not bothersome or hurtful for the user and attendant.

Disengage the steering mechanism

Going up a steep slope or over an obstacle requires the assistance of an attendant. Therefore it is necessary, for the attendant to move the wheelchair, to disengage the ball joint system from the fork in order to release the front directional wheel.

1. Press the end of the disengaging spring © .
2. Release the vertical axle © from its support.
3. Reverse the procedure to reinstall.

4.5 Posture belt

The wheelchair can be equipped with a posture belt. It prevents the user from sliding downward in the wheelchair or from falling out of the wheelchair. The posture belt is not a positioning device.



WARNING!

Risk of serious injury / strangulation

A loose belt can allow the user to slip down and create a risk of strangulation.

- The posture belt should be mounted by a qualified technician and fitted by the responsible prescriber.
- Always make sure that the posture belt is tightly fitted across the lower pelvis.
- Each time the posture belt is used, check if it fits properly. Changing the seat and/or backrest angle, the cushion and even your clothes influence the fit of the belt.

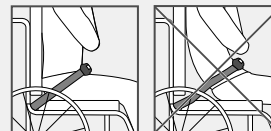

**WARNING!****Risk of serious injury during transport**

In a vehicle, a user in his wheelchair must be secured by a safety belt (3-point belt). A posture belt only is not sufficient as a personal restraint device.

- Use the posture belt as a complement, but not as a substitute to the 3-point safety belt, when transporting the wheelchair user in a vehicle.

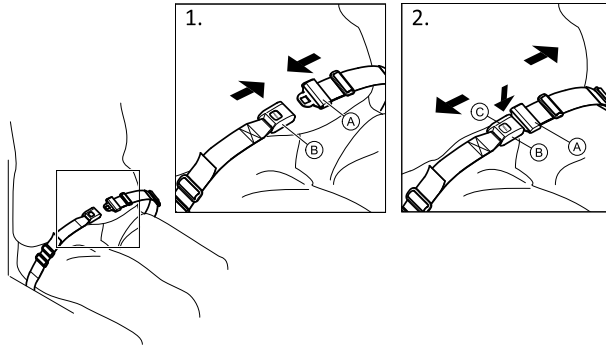
Closing and opening the posture belt

Ensure that you are sitting fully back in the seat and that the pelvis is as upright and symmetrical as possible.

1. To close, push the catch (A) into the buckle clasp (B).
2. To open, push the PRESS button (C) and pull the catch (A) out of the buckle clasp (B).

Adjusting the length

The posture belt has the good length, when there's just sufficient space for a flat hand between body and belt.

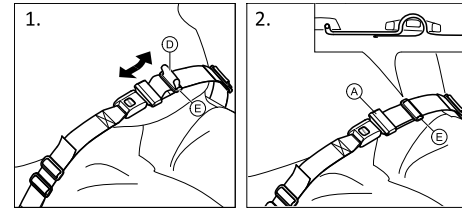

1. Shorten or extend the loop (D) as required.
2. Thread loop (D) through catch (A) and plastic buckle (E) until the loop is flat.

If this adjustment is not sufficient, it might be required to re-fit the posture belt at the fixations.

Fitting the posture belt at the fixations**CAUTION!**

- Thread the belt loop through both plastic buckles to avoid the belt from loosening.
- Do the adjustments on both sides equally, so that the buckle clasp remains in a central position.
- Make sure that the belts do not get caught in the spokes of a rear wheel.

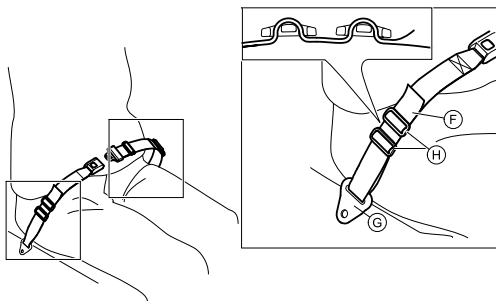

1. Thread the loop (F) through the fixation on the chair (G) and then through BOTH plastic buckles (H).

4.6 Headrest

 The height and the removal are operated by the handwheel. The bar is equipped with an adjustable stop block.

Height adjustment

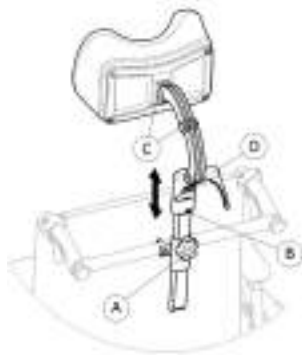

1. Loosen the screw in the stop block (B).
2. Loosen the handwheel (A).
3. Adjust the headrest to the desired position.
4. Re-tighten the handwheel (A) down to the top of the headrest attachment.
5. Slide the stop block (B).
6. Re-tighten the screw .

 It is now possible to remove the headrest and reinsert it in the desired position without further adjustments.

Depth / angle adjustment

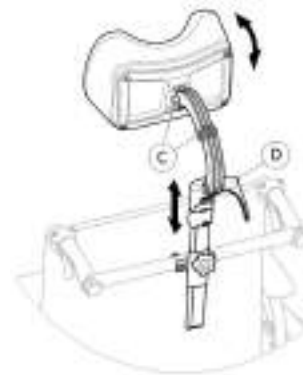

1. Loosen the handle (D).
2. Loosen the screws (C).
3. Adjust the depth and angle of the headrest.
4. Re-tighten the handle and the screws.

4.7 Lateral positioning pads (for adjustable backrest cover only)



WARNING!

Risk of trapping

- Be careful not to trap your trunk between the two lateral positioning pads during front or lateral transfers; when the user is moving in the wheelchair.



CAUTION!

Risk of uncomfortable posture

- Insufficient space between the lateral positioning pads can be uncomfortable for certain users.
- This adjustment must be performed by a qualified technician upon agreement by a prescribing physician.
 - Consult with your dealer.



The lateral positioning pads can be adjusted in height and sideways.

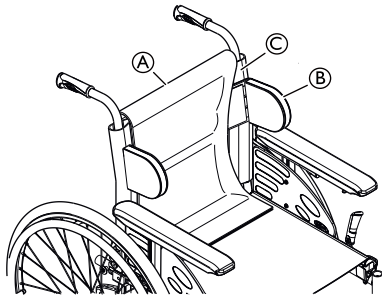

1. Remove the backrest cushion (A).
2. Adjust the lateral positioning pads (B) in height and sideways to the required position with the Velcro® of the backrest cover (C).
3. Ensure that the two Velcro® surfaces (pads and back cover) are set correctly.
4. Put the backrest cushion (A) back in place.

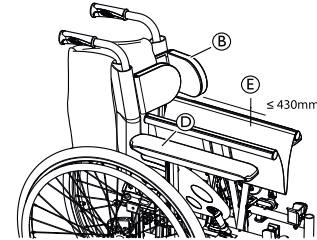

The lateral positioning pads (B) must be located above the arm pad (D) in order to be able to fold the wheelchair.



If the seat width is larger than 430 mm (E), the lateral positioning pads (B) must be removed before folding the wheelchair.

4.8 Tipper aid

With the tipper aid, an assistant can tip the wheelchair more easily, in order to navigate steps for example.

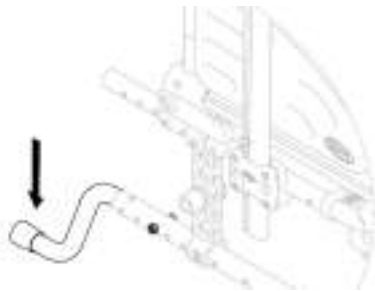

WARNING!

Risk of overturning

– Ensure that the tipper aid does not project beyond the external diameter of the rear wheel.

1. Hold the wheelchair by the push handles.
2. Press the tipper aid with your foot and hold the wheelchair in the tipped position until you have overcome the obstacle.

4.9 Table tray



WARNING!

Risk of tipping / injury

– Max load on the table: 8 kg



CAUTION!

Risk of discomfort / minor bruises

– Make sure that the elbows of the user are placed on the table when pushing the wheelchair. If the elbows protrude from the table while pushing the wheelchair, there is a risk of discomfort or minor bruises.

Depth adjustment

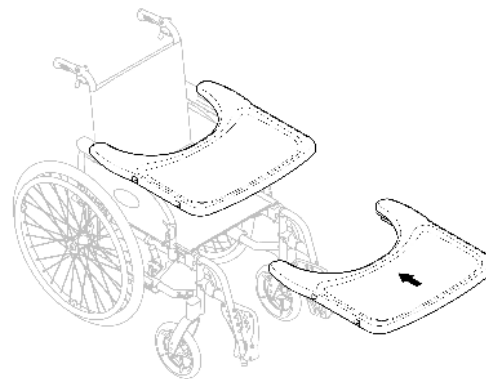

Slide the table tray forwards or backwards to adjust to the required depth.



CAUTION!

Risk of discomfort

– When adjusting the depth of the table, make sure not to squeeze the stomach of the user.

4.10 Half tray



WARNING!

Risk of falling / injury

- The half tray must never be used as a replacement for the posture belt.



WARNING!

Risk of tipping / injury

- Max load on the half tray: 1.5 kg



CAUTION!

Risk of discomfort / minor bruises

- Make sure that the elbow of the user are placed on the half tray when propelling the wheelchair. If the elbow protrudes from the wheelchair while propelling the wheelchair, there is a risk of discomfort or minor bruises.



CAUTION!

Risk of pinching fingers

- There is a mechanism below the half tray where you could trap your fingers.
- Be careful when adjusting the tray or when using the swing-away function.



The half tray can be adjusted in width and swung away.

Mounting the half tray

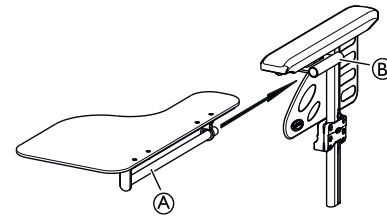

1. Insert the tube of the half tray (A) into its support (B) below the arm pad.

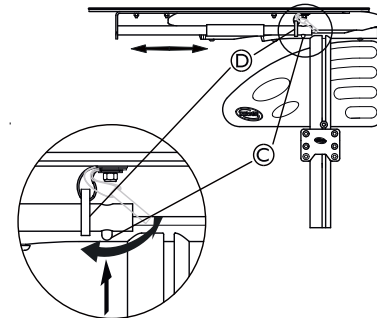

2. Push on the push pin (C) and insert the ring (D) on the tube (A).
3. Release the push pin (C).

Adjusting the depth of the half tray

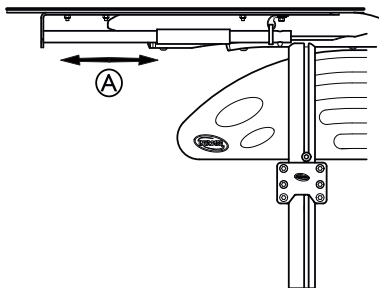

1. Slide the half tray (A) forwards or backwards to adjust to the required depth.



CAUTION! **Risk of discomfort**

- When adjusting the depth of the half tray, make sure not to squeeze the stomach of the user.

Swing away the half tray

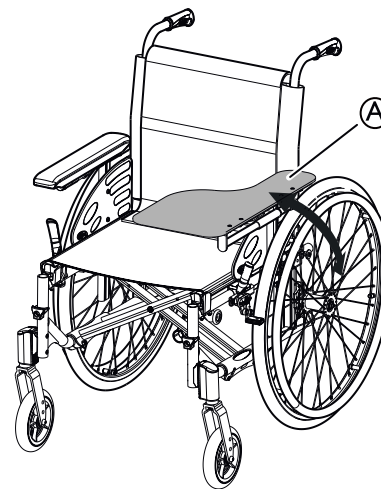

1. The half tray (A) can be swung away for the front transfer of the user.

4.11 Add a half tray cushion

A cushion for the half tray can be placed on the half tray in order to have a softer surface for the arms and elbows.

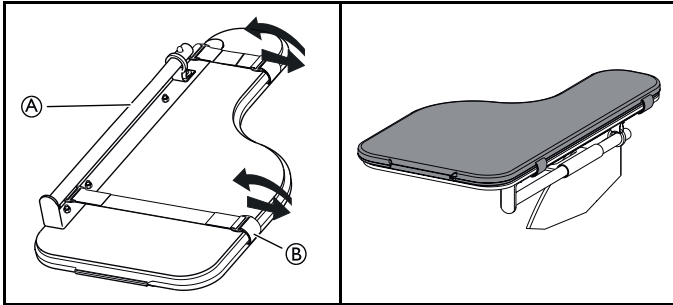

1. Place the cushion for the half tray (A) on the tray.
2. Place the attachment straps (B) into the plastic buckle and around the half tray (A).

4.12 Drip stand



WARNING!

Risk of tipping / injury

– Max load on the drip stand: 5 kg (2 x 2,5 kg)



The rod of the drip stand must always be placed in a vertical position, i.e. in a 90 degree angle to the ground, no matter the position of the backrest or the wheelchair.



Height/Angle adjustment



1. Loosen the lever (A).
2. Adjust the drip stand to the desired height or/and angle.
3. Firmly tighten the lever (A).

4.13 Transfer kit wheels

If your wheelchair is too wide for certain applications, e.g. trains/aeroplanes, narrow passageways, narrow doors, the transfer kit wheels can be used.



WARNING!

– When using transfer kit wheels, the parking brakes no longer have any effect and you cannot control your wheelchair via the handrims.

The transfer kit wheels are attached directly to the rear frame as an option.



WARNING!

Risk of tipping sideways

– Make sure that anti-tippers with transfer kit wheels are installed on both sides of the wheelchair.

Switching to Transfer kit wheels

1. Activate the anti-tippers with transfer kit wheels on both sides,
→ 3.9 *Anti-tipper*, page 26.
2. With the help of an assistant, remove the rear wheel,
→ 7.4 *Removing and fitting the rear wheels*, page 54 and lower the wheelchair to the transfer kit wheel.
3. Repeat the process on the other side.

Switching from Transfer kit wheels to rear wheels

1. With the help of an assistant, fit the rear wheel back onto the removable axle,
→ 7.4 *Removing and fitting the rear wheels*, page 54 and lower the wheelchair to the rear wheel.
2. Repeat the process on the other side.

4.14 Air pump

The air pump is fitted with a universal valve connection. Using the correct valve connection depends on the inner tube valve type.

1. Remove the dust cap from the valve connection.
2. Push the valve connection onto the open valve on the wheel and pump the wheel up.



There are two types of pumps available:

- Low pressure <6 bars
- High pressure >6 bars

Instruction for use printed on the packaging.

4.15 Passive illumination

You can attach reflectors to the rear wheels.

4.16 Cane holder

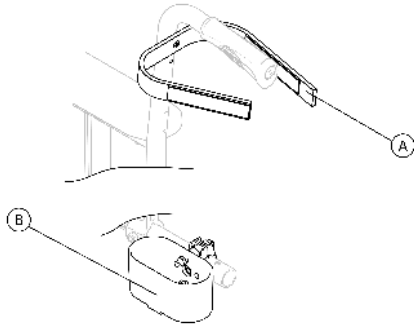

WARNING!

Risk of overturning

– Ensure that the cane holder does not project beyond the external diameter of the rear wheel.

1. Place the cane in the holder (B).
2. Fix the top of the cane to the backrest (A).

5 Setup

5.1 Safety information



CAUTION!

Risk of injury

- Before using the wheelchair, check its general condition and its main functions, 8.2 *Maintenance Schedule, page 61.*

Your authorized dealer will supply your wheelchair ready for use. Your dealer will explain the main functions and ensure that the wheelchair meets your needs and requirements.

Adjustments of the axle position and the front wheel supportors must be carried out by an authorized dealer.

If you receive your wheelchair folded, please read section 7.2 *Folding and unfolding the wheelchair, page 52.*

6 Using the wheelchair

6.1 Safety information

**WARNING!****Risk of accidents**

Uneven tire pressure can have a huge effect on handling.

- Check the tire pressure before each journey.

**WARNING!****Risk of falling out of the wheelchair**

When using too small front wheels the wheelchair could get stuck at curbs or in floor grooves.

- Make sure that the front wheels are suitable for the surface you're driving on.

**CAUTION!****Risk of crushing**

There may be a very small gap between the rear wheel and the mudguard/ armpad with the risk that you could trap your fingers.

- Ensure that you always propel your wheelchair using the handrims only.

**CAUTION!****Risk of crushing**

There may be a very small gap between the rear wheel and the parking brake with the risk that you could trap your fingers.

- Ensure that you always propel your wheelchair using the handrims only.

6.2 Braking during use

Whilst you are moving, you brake by transferring force to the handrim with your hands.



WARNING!

Risk of overturning

If you apply the parking brakes while you are moving, the direction of movement can become uncontrollable and the wheelchair may stop suddenly, which can lead to a collision or to you falling out.

- Never apply the parking brakes while you are moving.



WARNING!

Risk of falling out of the wheelchair

If the wheelchair is rapidly decelerated by an assistant pulling at the push handles, the user may fall out of the wheelchair.

- Always apply the posture belt if present.
- Make sure your assistant has been trained individually in transferring occupied wheelchairs.
- Operate the two brakes simultaneously and do not take slopes exceeding 7° to ensure perfect control of the wheelchair steering.
- Always use the parking brakes to secure the wheelchair during short or long stops.



CAUTION!

Risk of burning your hands

If you brake for a long time, a lot of frictional heat is produced at the handrims (especially anti slip handrims).

- Wear suitable gloves.

1. Hold the handrims and press evenly with both hands until the wheelchair stops.

Braking with an assistant

With an assistant's brake (drum brake) an assistant can brake the wheelchair while it is moving. The assistant's brake can also be used as a parking brake.



1. To brake, pull the brake lever (A) on the push handle.
2. To park, pull the brake lever firmly until the safety lever (B) engages.
3. To release, pull the brake lever and release the safety lever underneath the brake lever.

6.3 Move to/from the wheelchair



WARNING!

Risk of overturning

There is a high risk of overturning during the transfer.

- Only get in and out without assistance if you are physically able to do so.
- When transferring, position yourself as far back as possible in the seat. This will prevent damaged upholstery and the possibility of the wheelchair tipping forward.
- Make sure that both castors are facing straight to the front.



WARNING!

Risk of overturning

The wheelchair could tip forwards if you stand on the footrest.

- Never stand on the footrest when getting in and out.



CAUTION!

If you release or damage the brakes the wheelchair could roll away out of control.

- Do not support yourself on the brakes when getting in and out.



IMPORTANT!

The mudguards and armrests could become damaged.

- Never sit on the mudguards or armrests when getting in and out.



1. Propel the wheelchair as near as possible to the seat that you want to move to.
2. Apply the parking brakes.
3. Remove the armrests or move them upwards out of the way.
4. Detach the legrests or swing them outwards.
5. Place your feet on the ground.
6. Hold the wheelchair and, if necessary, also hold a fixed object in the vicinity.
7. Move slowly to chair.

6.4 Driving and steering the wheelchair

You drive and steer the wheelchair using the handrims. Before driving without an assistant you must find your wheelchair's tipping point.



WARNING!

Risk of tipping

The wheelchair can tip backwards if it is not fitted with an antitipper. When finding the tipping point, an assistant must stand immediately behind the wheelchair to catch it if it tips over.

- To prevent tipping, install an antitipper device.



WARNING!

Risk of tipping

The wheelchair can tip forwards.

- When setting up your wheelchair, test its behavior in terms of tipping forward and adjust your driving style accordingly.



CAUTION!

A heavy load hanging on the backrest can affect the wheelchair's centre of gravity.

- Change your driving style accordingly.

Finding the tipping point



1. Release the brake.
2. Roll backwards a short distance, grasp both handrims firmly and push forwards with a slight kick.
3. The shift in weight and steering in opposite directions with the handrims will enable you to identify the tipping point.

6.5 Negotiating steps and kerbs



WARNING!

Risk of overturning

When negotiating steps you could lose your balance and tip the wheelchair over.

- Always approach steps and kerbs slowly and carefully.
- Do not go up or down steps that are higher than 25 cm.



CAUTION!

An activated anti-tipper prevents the wheelchair from tipping backwards.

- Deactivate the anti-tipper before going up or down steps or kerbs.

Going down a step with an assistant

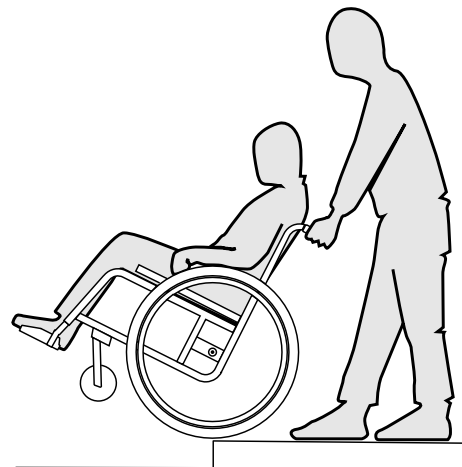

1. Move the wheelchair right up to the kerb and hold the handrims.
2. The assistant should hold both push handles, place one foot on the tipper aid (if installed) and tilt the wheelchair backwards so that the front wheels lift off the ground.
3. The assistant should then hold the wheelchair in this position, push it carefully down the step and then tilt it forwards until the front wheels are back on the ground.

Going up a step with an assistant



WARNING!

Risk of serious injuries

Going up steps and kerbs frequently can result in earlier than expected fatigue break of the wheelchair backrest. The user might fall out of the wheelchair.

– Always use a tipper aid when going up steps or kerbs.

1. Move the wheelchair backwards until the rear wheels touch the kerb.
2. The assistant should tilt the wheelchair using both push handles so that the front wheels lift off the ground, then pull the rear wheels over the kerb until the front wheels can be placed back on the ground.

Going down a step without an assistant

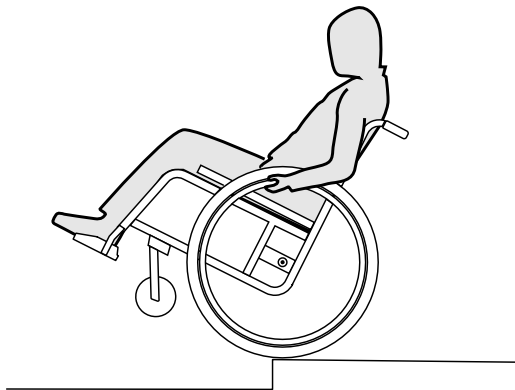

WARNING!

Risk of tipping

When going down a step without an assistant you could tip over backwards if you cannot control your wheelchair.

- First learn how to go down a step with an assistant.
- Learn how to balance on the rear wheels, *6.4 Driving and steering the wheelchair, page 46.*

1. Move the wheelchair right to the kerb, lift the front wheels and keep the wheelchair balanced.
2. Now slowly roll both rear wheels over the kerb. While doing this, hold the handrims firmly with both hands until the front wheels are back on the ground.

6.6 Going up and down stairs



WARNING!

Risk of overturning

When negotiating stairs you could lose your balance and overturn your wheelchair.

- Always use two assistants when negotiating stairs with more than one step.



1. You can go up and down stairs by taking them one step at a time, as described above. The first assistant should stand behind the wheelchair holding the push handles. The second assistant should hold a solid part of the front frame to steady the wheelchair from the front.

6.7 Negotiating ramps and slopes



WARNING!

Risk due to wheelchair being out of control

When negotiating slopes or gradients your wheelchair could tip backwards, forwards or sideways.

- Always have an assistant behind the wheelchair when approaching long slopes.
- Avoid lateral slopes.
- Avoid slopes of more than 7°.
- Avoid jerking when changing direction on a slope.



CAUTION!

Your wheelchair could run away even on slightly sloping ground if you do not control it using the handrims.

- Use the parking brakes if your wheelchair is stationary on sloping ground.

Going up slopes

To go up a slope, you must create some momentum, keep up the momentum and control the direction at the same time.

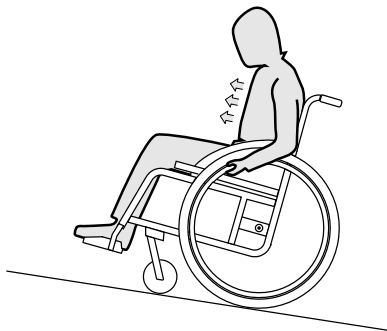

1. Bend your upper body forwards and propel the wheelchair with quick, powerful strokes on both handrims.

Going down slopes

When going down slopes, it is important to control your direction and particularly your speed.

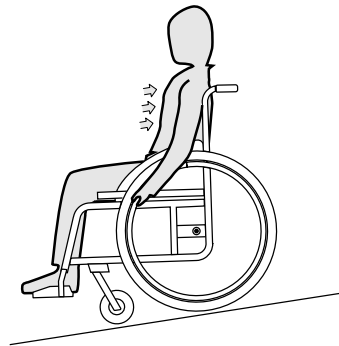

1. Lean back and carefully allow the handrims to run through your hands. You should be able to stop the wheelchair at any time by gripping the handrims.



CAUTION!

Risk of burning your hands.

If you brake for a long time, a lot of frictional heat is produced at the handrims (especially anti slip handrims).

– Wear suitable gloves.

6.8 Stability and balance when seated

Some everyday activities and actions require you to lean forwards, sideways or backwards out of the wheelchair. This has a major effect on the wheelchair's stability. To keep your balance at all times, proceed as follows:

Leaning forwards



WARNING! **Risk of falling out**

If you lean forwards out of the wheelchair you could fall out of it.

- Never bend too far forwards and do not shift forwards in your seat to reach an object.
- Do not bend forwards between your knees to pick up something off the floor.



1. Point the front wheels forwards. (To do this, move your wheelchair forwards slightly then back again.)
2. Apply both parking brakes.
3. When leaning forwards your upper body must remain over the front wheels.

Reaching backwards



WARNING! **Risk of falling out**

If you lean too far backwards you could tip your wheelchair over.

- Do not lean out over the backrest.
- Use an antitipper device.

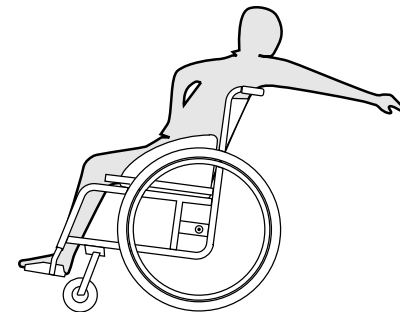

1. Point the front wheels forwards. (To do this, move your wheelchair forwards slightly then back again.)
2. Do not apply the parking brakes.
3. When reaching backwards do not reach so far that you have to change your sitting position.

7 Transport

7.1 Safety information



WARNING!

Risk of injury if the wheelchair is not properly secured

In the event of an accident, braking manoeuvre, etc. you may suffer serious injuries from flying wheelchair parts.

- Always remove the rear wheels when transporting the wheelchair.
- Firmly secure all wheelchair components in the means of transport to prevent them from coming loose during the journey.



IMPORTANT!

Excessive wear and abrasion could affect the strength of load-bearing parts.

- Do not pull your wheelchair across abrasive surfaces without the wheels fitted (e.g. pulling the frame over tarmac).

7.2 Folding and unfolding the wheelchair

Folding the wheelchair

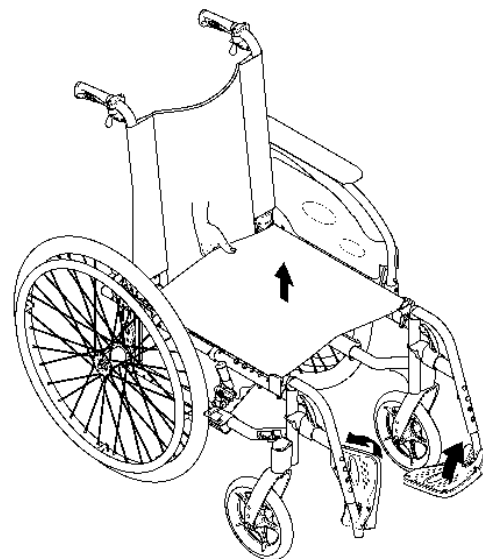

1. Remove the seat cushion, if present.
2. Fold the backbrace, if present.
3. Fold the foot plates upwards.
4. Pull the seat cover upwards.
5. You can fold the backrest frontwards, if your wheelchair is fitted with an angle adjustable and fold down backrest.
6. Pull the pull-cord upwards at the back of the wheelchair. The angle adjustable and fold down backrest folds forwards.

Unfolding the wheelchair

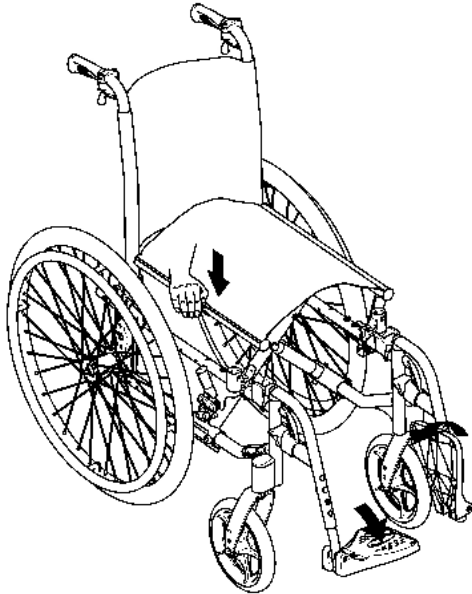

4. Put the wheelchair back completely on the floor and check that the seat edges on both sides are in the guide components.
5. If your wheelchair is fitted with an angle adjustable and fold down backrest, pull up the backrest at the push-handles until the ratchet bolts engage in the lateral supports.
6. Fold the foot plates down.
7. Unfolding the backbrace, if present.

7.3 Lifting the wheelchair



IMPORTANT!

- Never lift the wheelchair by removable parts (armrests, footrests).
- Ensure the backrest posts are securely in place.



CAUTION!

Risk of getting fingers caught

There is a risk of getting your fingers caught between the seat edge and the frame.

- Never clasp the seat edge with your fingers.

1. Position the wheelchair next to you.
2. Tilt the wheelchair, if possible, gently towards you.
3. With your hand flat, press the seat edge closest to you, so that the seat surface flattens out.

1. Fold the wheelchair, see chapter 7.2 *Folding and unfolding the wheelchair, page 52*
2. Always lift the wheelchair by gripping the frame at points **A**.

7.4 Removing and fitting the rear wheels



WARNING!

Risk of overturning

If the removable axle of a rear wheel is not fully engaged, the wheel can become loose during use. This can lead to overturning.

- Always ensure that the removable axles are fully engaged whenever you fit a wheel.

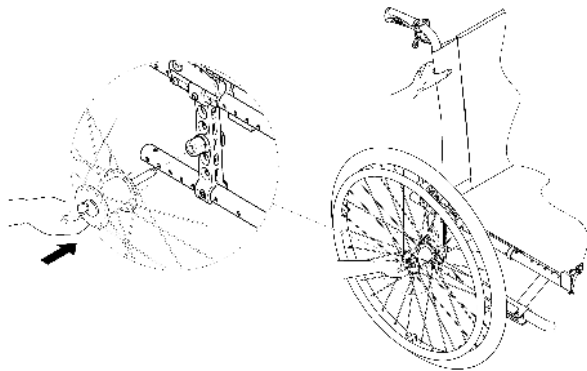

Removing the rear wheels

1. Release the brakes.
2. With one hand, hold the wheelchair upright.

3. With the other, hold the wheel through the external spoke rim around the wheel hub.
4. Using your thumb, press the removable axle button **A**. Keep it pressed and pull the wheel out of the adapter sleeve **B**.

Fitting the rear wheels

1. Release the brakes.
2. With one hand, hold the wheelchair upright.
3. With the other, hold the wheel through the external spoke rim around the wheel hub.
4. Using your thumb, press the removable axle button and hold it down.
5. Push the axle into the adapter sleeve **B** up to the stop.
6. Release the removable axle button and make sure that the wheel is secure.

7.5 Transporting the occupied wheelchair in a vehicle

Even when the wheelchair is properly secured and the following rules are met, injuries to passengers may occur in a collision or sudden stop. Therefore Invacare strongly recommends transferring the wheelchair user to the vehicle seat with the seatbelt on. Do not make alterations or substitutions to points of the wheelchair (structure, frame or parts) without the written consent of Invacare Corporation. The wheelchair has been successfully tested according to the requirements of ISO 7176–19 (Frontal impact).



WARNING!

Risk of serious injury or death

To use the wheelchair as a seat in a vehicle the backrest height minimum must be at least 400 mm.

To transport the wheelchair with user in a vehicle, a restraint system must be installed in the vehicle. Wheelchair tie-downs and occupant restraint systems must be approved according to ISO 10542-2. Contact your local Invacare authorized dealer for more information on getting and installing an approved and compatible restraint system.



WARNING!

If, for some reason, it is impossible to transfer the wheelchair user to a vehicle seat, the wheelchair can be used as a seat in a vehicle if the following procedures and regulations are followed. A transportation kit (optional) have to be fitted on the chair for such a purpose.

- The wheelchair must be secured in the vehicle with a 4-point wheelchair restraint system.
- The user must wear a 3-point passenger restraint system secured to the vehicle.
- The user must be additionally secured with a posture belt in the wheelchair.



WARNING!

Safety restraint devices must only be used when the wheelchair user's weight is 22 kg or more (ISO-7176-19).

- Do not use the wheelchair as a seat in a vehicle when the user weight is lower than 22 kg.



WARNING!

- Before journey contact transporter and request information about the capability for the below required equipment.
- Make sure there is sufficient free space around the wheelchair and user to avoid the user making contact with other vehicle occupants, unpadded parts of the vehicle, wheelchair accessories or anchor points of the restraint system.



WARNING!

- Make sure the tie-down points at the wheelchair are not damaged and that the parking brakes are fully functional.
- It's recommended to use puncture-proof tires during transport to avoid brake problems due to reduced tire pressure.



WARNING!

- Injury or damage may occur from wheelchair components or accessories loosened during a collision or sudden stop.
- Ensure all removable or detachable components and accessories are removed from the wheelchair and securely stored in the vehicle.
 - It is essential to have your wheelchair checked by a specialist dealer after an accident, collision etc.



IMPORTANT!

- It is recommended that training be given on the proper use of a restraint system product.
- Refer to the user manuals supplied with the restraint systems.
 - The following illustrations may differ depending on the restraint system supplier.

Securing the wheelchair with a 4-point restraint system

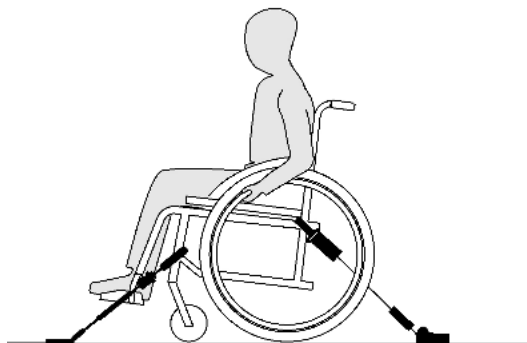

WARNING!

- Place the wheelchair with the user forward-facing in direction of vehicle travel.
- Apply the wheelchair parking brakes.
- Activate anti-tipper (if installed).

The wheelchair tie-down positions where the restraint system straps must be placed are marked with snap hook symbols (see following figures and section 2.3 *Labels and symbols on the product, page 9*).

1. Using the front and rear straps of the 4-point restraint system, secure the wheelchair to the vehicle mounted rails. Refer to the user manual supplied with 4-point restraint system.

Front side tie-down positions for belt straps:

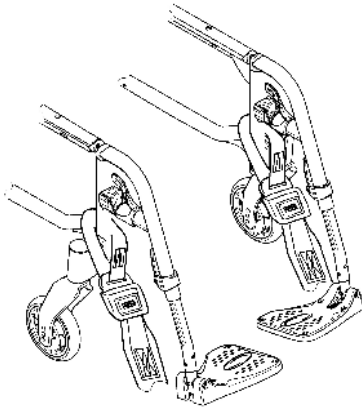
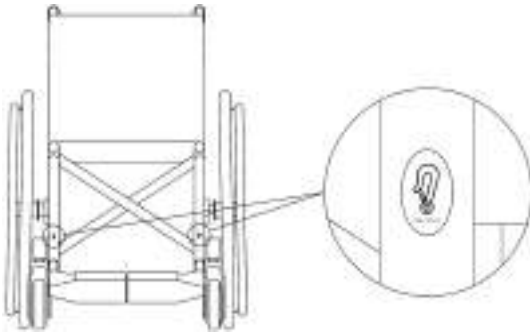

1. Attach the front straps above the castor supporters as shown in the figure above (see location of the attachment labels).
2. Attach front straps to the rail system referring to best practice recommended instructions from the safety belt manufacturer.
3. Release parking brakes and apply tension front straps by pulling the wheelchair backwards from the rear.
4. Re-apply parking brakes.

Rear side tie-down positions for snap hooks:

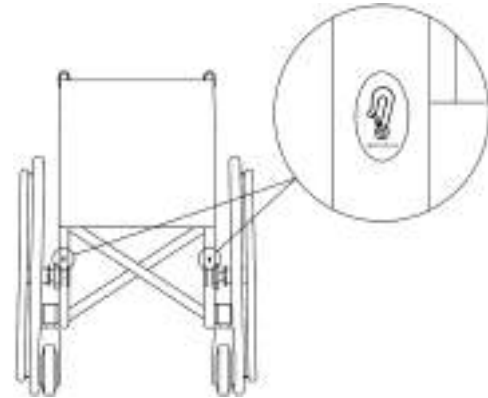

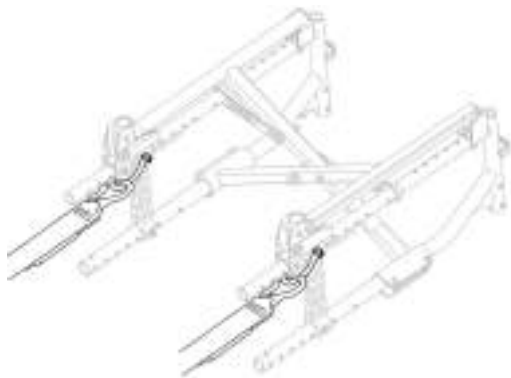

1. Attach the snap hooks to the orange rings as shown in the two figures above (see location of the attachment labels).
2. Attach rear straps to the rail system referring to best practice recommended instructions from the safety belt manufacturer.
3. Tighten the straps.

! **IMPORTANT!**

- Make sure that the snap hooks are covered with slip resistant material to avoid laterally slipping on the axle.

! **IMPORTANT!**

- Check the plungers are fully engaged on both sides and located in the same position of the cut-out section of the rail.
- Make sure that the angle between the rails and the straps lies between 40° and 45°.

Fit posture belt



WARNING!

The posture belt must be used in addition to but never as a substitute for an approved passenger restraint system (3-point belt).

1. Adjust posture belt to fit the wheelchair occupant, see section 4.5 *Posture belt*, page 32.

Fit specific attachment kit for Comfort version only



WARNING!

A specific attachment kit (available as an accessory) is mandatory to be used for car transportation, no other attachment is permitted ! A mounting instruction is delivered with the kit, contact your authorized dealer for further information.

Fastening the 3-point passenger restraint system



IMPORTANT!

The illustration above may differ depending on the restraint system supplier.



WARNING!

- Ensure the 3-point passenger restraint system fits as tightly across the user's body as possible without discomfort and no part is twisted.
- Ensure the 3-point passenger restraint system is not held away from the user's body by parts of the wheelchair such as armrests or wheels etc.
- Ensure the user restraint has a clear path from the user to the anchor point without interference by any part of the vehicle, wheelchair, seating or accessory.
- Ensure the lap belt fits snugly over the occupant's pelvis and is not allowed to ride up into the abdominal area.
- Ensure the user is able to reach the release mechanism unaided.



1. Attach the 3-point passenger restraint system referring to the user manual supplied with your 3-point restraint system.



IMPORTANT!

- Apply the posture belt of the 3-point passenger restraint system low across the pelvis so that the angle of the posture belt is within the preferred zone (A) of 30° to 75° to the horizontal. A steeper angle is preferred, but never exceeding 75°.

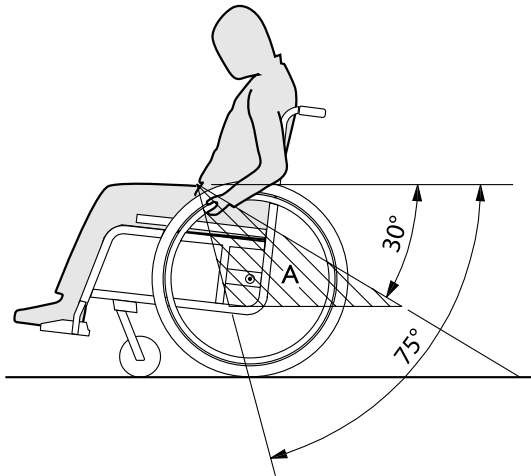

8 Maintenance

8.1 Safety information



WARNING!

Some materials deteriorate naturally over time. This could result in damage to wheelchair components.

- Your wheelchair should be checked by a authorized dealer at least once a year or if it has not been used for a long period.



Your Invacare authorized dealer can provide help in carrying out regular maintenance. To find an authorized dealer near you, contact the Invacare distributor for your country (end of this document).



Packaging for return

The wheelchair shall be sent to the authorized dealer in an appropriate packaging to avoid damage during the shipment.

8.2 Maintenance Schedule

To ensure safe and reliable operation, carry out the following checks and maintenance regularly or have it carried out by another person.

	weekly	monthly	annually
Check the tire pressure	x		
Check that rear wheels are seated correctly	x		
Check posture belt	x		
Visual check		x	
Check the folding mechanism		x	
Clean the front wheels		x	
Check bolts		x	
Check spokes		x	
Check parking brakes		x	
Have wheelchair checked by an authorized dealer			x

Check the tire pressure

1. Check the tire pressure, *3.10 Tires, page 27*.
2. Inflate the tires to the required pressure.

3. Check the tire tread at the same time.
4. If necessary, change the tires.

Check that rear wheels are seated correctly

1. Pull on the rear wheel to check that the removable axle is seated correctly. The wheel should not come off.
2. If the rear wheels are not engaged properly, remove any dirt or deposits. If the problem persists, have the removable axles re-fitted by an authorized dealer.

Check posture belt

1. Check that the posture belt is adjusted correctly.

! IMPORTANT!

- Loose posture belts must be adjusted by an authorized dealer.
- Damaged posture belts must be replaced by an authorized dealer.

Visual check

1. Examine your wheelchair for loose parts, cracks or other defects.
2. If you find anything, have your wheelchair checked immediately by an authorized dealer.

Check the folding mechanism

1. Check that the folding mechanism is easy operating.

Clean the front wheels

1. Check that the front wheels turn freely.
2. Remove any dirt or hair from the front wheel bearings.

Check the bolts

Bolts can work loose through constant use.

1. Check that the bolts are tight (on the footrest, seat cover, sides, backrest, frame, seat module).
2. Tighten any loose bolts with the suitable torque. Therefore refer to the Service Manual, available on the internet at www.invacare.eu.com.

! IMPORTANT!

- Safety nuts and bolts lose their effectiveness as a result of repeated loosening and tightening.
 - Safety nuts and bolts must be replaced by an authorized dealer.

Check the spoke tension

The spokes should not be loose or distorted.

1. Loose spokes must be tightened by an authorized dealer.
2. Broken spokes must be replaced by an authorized dealer.

Check the parking brakes

1. Check that the parking brakes are positioned correctly. The brake is set correctly if the brake shoe depresses the tire by a few millimeters when the brake is applied.
2. If you find that the setting is not correct, have the brakes correctly set by an authorized dealer.

! IMPORTANT!

- The parking brakes must be reset after replacing the rear wheels or changing their position.

Checking after a heavy collision or blow

! IMPORTANT!

The wheelchair can sustain visibly undetectable damage as a result of a heavy collision or hard blow.

- It is essential to have your wheelchair checked by an authorized dealer after a heavy collision or hard blow.

Repairing or changing an inner tube

1. Remove the rear wheel and release any air from the inner tube.
2. Lift one tire wall away from the rim using a bicycle tire lever. Do not use sharp objects such as a screwdriver which could damage the inner tube.
3. Pull the inner tube out of the tire.
4. Repair the inner tube using a bicycle repair kit or, if necessary, replace the tube.
5. Inflate the tube slightly until it becomes round.
6. Insert the valve into the valve hole on the rim and place the tube inside the tire (the tube should lie right round the tire with no creases).
7. Lift the tire wall over the edge of the rim. Start close to the valve and use a bicycle tire lever. When doing this, check all the way round to ensure that the inner tube is not trapped between the tire and the rim.
8. Inflate the tire to the maximum operating pressure. Check that no air is escaping from the tire.

Spare parts



All spare parts may be obtained from an Invacare authorized dealer. A current list of spare parts is available on the internet at www.invacare.eu.com.

8.3 Cleaning

Your wheelchair will serve you well for many years if you clean it regularly.

! IMPORTANT!

- Sand and seawater can damage the bearings and steel parts can rust if the surface is damaged.
 - Only expose the wheelchair to sand and seawater for short periods and clean it after every trip to the beach.

! IMPORTANT!

- Do not use coarse abrasives, aggressive cleaning products or high-pressure cleaners. Never use acids, alkalines or solvents such as acetone or cellulose thinner.
 - Always use ordinary household cleaning agents.

1. Clean the cushions and metal parts with a soft, damp cloth.
2. Dry the wheelchair carefully with a cloth after using it in the rain.
3. If the wheelchair is dirty, wipe off the dirt as soon as possible with a damp cloth and dry it carefully.



Regular cleaning will reveal loose or worn parts and enhance the smooth operation of your wheelchair. To operate properly and safely, your wheelchair must be cared for just like any other vehicle. For upholstery that is severely stained or surface finish that is badly damaged, contact an authorized dealer for further information.

Cleaning upholstery

For cleaning upholstery refer to the instructions on the label on the seat, cushion and backrest cover.

Cleaning metal surfaces

Hot water and mild detergent on soft cloth should be used to clean metal surfaces.

1. Wipe down with damp cloth.
2. Dry surface by wiping down with dry cloth.

Car polish and soft wax can be used to remove abrasions and restore gloss.

Cleaning plastic surfaces

Plastic surfaces must be cleaned with soft cloth, mild detergent and hot water.



IMPORTANT!

– Do not use solvents or kitchen cleaners to clean plastic surfaces.

1. Rinse surface with clean water.
2. Dry surface by wiping down with dry cloth.

8.4 Disinfection

The wheelchair may be disinfected by spraying or wiping with tested, approved disinfectants.



Spray a soft cleaning and disinfecting product (bactericidal and fungicide meeting the EN1040 / EN1276 / EN1650 standards) and follow the instructions given by the manufacturer.

9 Troubleshooting

9.1 Safety information

Faults may arise as a result of daily use, adjustments or changing demands on the wheelchair. The table below shows how to identify and repair faults.

**CAUTION!**

– Contact your authorized dealer immediately if you notice a fault with your wheelchair, e.g. a significant change in handling.

**IMPORTANT!**

– Some of the actions listed must be carried out by an authorized dealer. These are indicated. We recommend that *all* adjustments are carried out by an authorized dealer.

9.2 Identifying and repairing faults

Fault	Possible cause	Action
The wheelchair does not travel in a straight line	Incorrect tire pressure on one rear wheel	Correct tire pressure, → <i>3.10 Tires, page 27</i>
	One or more spokes broken	Replace faulty spoke(s), → authorized dealer
	Spokes tightened unevenly	Tighten loose spokes, → authorized dealer
	Front wheel bearings are dirty or damaged	Clean or replace the bearings, → authorized dealer
The wheelchair tips backwards too easily	Rear wheels are mounted too far forwards	Mount the rear wheels further back, → authorized dealer
	Back angle too large	Reduce the backrest angle, → authorized dealer
	Seat angle too large	Mount the front wheel upper on the front fork, → authorized dealer Select a smaller front fork, → authorized dealer
The brakes are gripping poorly or asymmetrically	Incorrect tire pressure in one or both rear tires	Correct tire pressure, → <i>3.10 Tires, page 27</i>
	Brake setting incorrect	Correct the brake setting, → authorized dealer
Rolling resistance is very high	Tire pressure in rear tires is too low	Correct tire pressure, → <i>3.10 Tires, page 27</i>
	Rear wheels not parallel	Ensure the rear wheels are parallel, → authorized dealer
The front wheels wobble when moving fast	Too little tension in front wheel bearing block	Tighten the nut on the bearing block axle slightly, → authorized dealer
	Front wheel has worn smooth	Change front wheel, → authorized dealer

Fault	Possible cause	Action
The front wheel is stiff or stuck	Bearings are dirty or faulty	Clean or replace the bearings, → authorized dealer
The wheelchair is very difficult to unfold	Backrest cover is too tight	Loosen the Velcro bands of the backrest cover a little, → <i>3.3.1 Backrest cover, page 13</i>

10 After Use

10.1 Storage



IMPORTANT!

Risk of damage to the product

- Do not store the product near heat sources.
- Never store other items on top of the wheelchair.
- Store the wheelchair indoors in a dry environment.
- Refer to temperature limitation in chapter *11.3 Environmental conditions, page 71*.

After long-term storage (more than four months) the wheelchair must be inspected in accordance to chapter *8 Maintenance, page 61*.

10.2 Re-use

The wheelchair is suitable for re-use. The following actions should be taken:

- Cleaning and disinfection, *8.3 Cleaning, page 63* and *8.4 Disinfection, page 64* in this manual.
- Inspection, *8.2 Maintenance Schedule, page 61* in this manual.
- The wheelchair should be adapted for the new user in accordance with the service documentation (available from the Invacare authorized dealer in your country).

10.3 Disposal

Be environmentally aware and dispose of your wheelchair properly. Disposal is subject to national and local regulations.



For correct disposal, contact your authorized dealer or ask your town or district council about local waste management companies.

11 Technical data

11.1 Dimensions and weight

All dimension and weight specifications refer to a wide range of the wheelchair in a standard configuration. Dimension and weight (based on ISO 7176-1/5/7) may alter according to different configurations. In some configurations, the wheelchair exceed the recommended dimensions for a wheelchair.

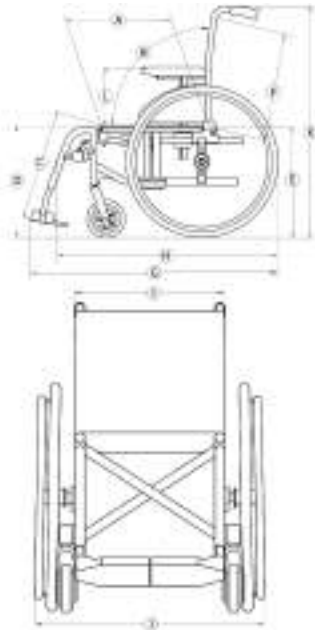

Ⓒ	Overall length with leg rests	962 – 1185 mm
Ⓙ	Overall width	570 – 710 mm
	Folded length	765 – 1200 mm
	Folded width	285 – 355 mm
	Folded height	795 – 1510 mm
	Total mass	from 12,3 – 28,2 kg
	Mass of the heaviest part	7,1 – 12,4 kg
	Static stability downhill	0° – 17°
	Static stability uphill	0° – 7°
	Static stability sideways	0° – 17°
	Seat plane angle	0° – 8°
Ⓐ	Effective seat depth	395 – 500 mm
Ⓛ	Effective seat width	370 – 505 mm, in increments of 25 mm
Ⓓ	Seat surface height at front edge	345 – 550 mm, in increments of 25 mm
Ⓔ	Seat surface height at rear edge	345 – 550 mm, in increments of 25 mm

Ⓑ	Backrest angle (Range)	-15° / +30°
	Backrest angle (fixed)	90°
	Backrest angle (adjustable)	90° (-15°/+15°) mm, step less
	Backrest angle (recliner)	90° (0°/+30°) mm, in increments of 10°
Ⓕ	Backrest height	325 – 610 mm
Ⓒ	Footrest to seat distance	160 – 510 mm, in increments of 10 mm
	Leg to seat surface angle	0° – 90°
Ⓕ	Armrest to seat height	Range: 170 – 300mm N°1: 200 – 280 mm N°2: 240 mm N°3: 170 – 295 mm N°4: 210 – 300 mm
	Front location of armrest structure	190 – 350mm
	Hand rim diameter	520 – 540 mm
	Horizontal location of axle	-55 / + 42,5 mm
	Minimum turning radius	790 mm
	Stowage width	250 – 320 mm
	Stowage height	566 – 1000 mm
	Stowage length	from 695 – 1130 mm

Ⓕ	Overall length without leg rests	720 – 860 mm
Ⓖ	Overall height	795 – 1510 mm
	Maximum user weight	125 kg
	Pivot width	1120 – 1505 mm
	Maximum slope angle brake	7° / 5° (with OAD brake)

11.2 Materials

Frame/backrest tubes	Aluminum, Steel
Upholstery (seat and backrest)	Foam PUR, Fabric Nylon and Polyester
Push handles	PVC
Plastic parts like brake handles, clothes guards, foot plates, armpads and parts of most accessories	Thermoplastic (e.g. PA, PP, ABS and PUR) according to marking on the parts
Folding mechanism / vertical brace / clamping parts / castor forks	Aluminum, Steel
Screws, washers and nuts	Steel



All materials used are corrosion-resistant. We use only REACH compliant materials and components.

11.3 Environmental conditions

Temperature limitation	– 20° C to + 40° C
Relative humidity	20% to 75%
Atmospheric pressure	800 hPa to 1060 hPa



Be aware that when a wheelchair has been stored under low temperatures, it must be adjusted to chapter 8 *Maintenance*, page 61 before use.

Invacare distributors

United Kingdom:

Invacare Limited
Pencoed Technology Park, Pencoed
Bridgend CF35 5AQ
Tel: (44) (0) 1656 776 222
Fax: (44) (0) 1656 776 220
uk@invacare.com
www.invacare.co.uk

Ireland:

Invacare Ireland Ltd,
Unit 5 Seatown Business Campus
Seatown Road, Swords, County Dublin
Tel : (353) 1 810 7084
Fax: (353) 1 810 7085
ireland@invacare.com
www.invacare.ie

Australia:

Invacare Australia PTY. Ltd.
1 Lenton Place, North Rocks NSW 2151
Australia
Phone: 1800 460 460
Fax: 1800 814 367
orders@invacare.com.au
www.invacare.com.au

New Zealand:

Invacare New Zealand Ltd
4 Westfield Place, Mt Wellington 1060
New Zealand
Phone: 0800 468 222
Fax: 0800 807 788
sales@invacare.co.nz
www.invacare.co.nz

Asia:

Invacare Asia Ltd.
1 Lenton Place, North Rocks NSW 2151
Australia
Phone: (61) (02) 8839 5333
Fax: (61) (02) 8839 5343
asiasales@invacare.com
www.invacare.com



Invacare France Operations
Route de St Roch
F-37230 Fondettes
France

1608467-B 2017-07-07



Making Life's Experiences Possible®



Yes, you can.®